

85ATX

4x4 ARTICULATED TRACTOR
280 HP (208 KW) / 260 HP (194 KW)



Gross Weight: 375,000lbs., 4,500 hrs per year

85ATX

4x4 ARTICULATED TRACTOR 280 HP (208 KW) / 260 HP (194 KW)



Extreme heavy duty upper and lower articulation joint with radial spherical bearings, oversized hardened pins, and welded cylinders with bushings



Individual gauges and indicators simplify operation troubleshooting and repair



Hood profile provides excellent visibility



Engine and transmission coolers with 8 fins per inch spacing reduce buildup of debris. Hood rolls up for easy cleaning

GAME tractors are designed and manufactured from the ground up for the most demanding conditions the world has to offer. Industrial frames, belly pans, articulation, drivelines, powertrain components, and hitches are standard.



Tilting platform provides unmatched access to powertrain and hydraulic components



Optional drawbars and 3-point hitches are built to withstand extreme applications



Rear frame accommodates multiple hitch configurations for high weight transfer, winches, and other equipment

GAME Equipment reserves the right to change specifications without notice. Some photos may contain optional equipment.

85ATX

4x4 ARTICULATED TRACTOR 280 HP (208 KW) / 260 HP (194 KW)

ENGINE

- Cummins QSL, 8.9 liter, Tier III electronic engine, 280HP (208KW) @ 2,100 RPM with a 307HP (228 KW) @ 1,800 RPM bulge, Peak torque of 1,050 LB-FT (1423 NM) @ 1,500 RPM
- Severe dust, dry, dual stage air cleaner with service indicator
- Spinning type dust pre-cleaner with automatic dust ejector
- Primary fuel/water separator with secondary fuel filter
- Large tropical radiator and oil coolers mounted on rubber isolators with 8 fins/inch spacing
- Manual hydraulic tilting hood allows easy cleaning of coolers and service of engine and under hood parts
- 130-gal (492-liters) steel fuel tank with lockable cap and 12-inch clean out door

Export Only Option:

- Cummins 6 CTA 8.3, 260HP (194 KW) @ 2,200 RPM, 825 FT-LB (1119 NM) @ 1,500 RPM mechanical fuel injection system

TRANSMISSION

- Converter driven, 6 forward/3 reverse, powershift with bump and automatic shifting
- Converter lock up in all gears
- Automatic selector switch
- Spring applied/hydraulic release parking brake
- Separate cooler/system isolate transmission from hydraulic system contamination

Optional:

- Direct drive powershift transmission with bump shifter and inching pedal - 11F/3R

AXLES

- All wheels are powered
- Heavy duty, planetary, dual reduction
- Oscillating front axle, rigid rear axle
- Internal oil bath service brakes
- 8.5C mechanics drivelines
- Hydraulically actuated locking differentials front and rear axles

CHASSIS

- Heavy duty welded frame

- Articulating joint with heavy duty radial spherical bearings and large hardened pins
- Dual, double acting heavy duty welded hydraulic steering cylinders with bushings
- Full belly pans and front pull hook
- Painted with yellow gloss finish

STANDARD EQUIPMENT

- Engine oil pressure gauge and indicator
- Engine coolant temperature gauge and indicator
- Voltage gauge
- Fuel gauge
- Tachometer with hour meter
- Hand and foot throttle
- Low hydraulic oil level light/indicator
- Transmission oil temperature gauge and indicator
- Transmission pressure gauge and indicator
- Oil filter service warning light/indicator

ELECTRICAL

- (3) 12-VDC, 950 CCA, 180 RC Group 31XHE heavy duty maintenance free commercial batteries
- 12-Volt DC, 160-Amp alternator
- Horn, reverse alarm, and master disconnect switch
- Four LED headlights in hood
- Two adjustable front and two rear/side LED work lights
- Two LED work lights in rear bumper
- Brake and indicator lights in rear bumper with warning lights top of cab viewable front and rear
- Strobe light

OPERATOR'S STATION

- Open station with welded steel canopy top
- Vinyl mechanical suspension seat with position adjustment and armrests
- Adjustable tilt and telescopic steering column
- Manual hydraulic tilting platform

Optional:

- Training seat
- A/C cab with rear wiper, with AM/FM radio, marine grade, USB, AUX port and Bluetooth

- Leather, heated, toggle link fully adjustable air ride suspension seat with armrests, 20-degree swivel right, 60-degree swivel left
- Electric cab/hood tilt

HYDRAULIC SYSTEM

- Open center pump for brakes, steering, and implement valve
- 55-gal pressurized hydraulic tank with 100% filtration and 12-inch clean out door
- 2 bank, cylinder spools, open center valve
- Accumulator for emergency braking

MISC OPTIONS

- Cable operated 4-bank control valves
- Air compressor, tank, trailer park and service brakes via foot & lever
- 7-pin electrical connector capable of multiple trailer operation
- Hydraulic brake ports on rear for trailer
- Heavy duty fixed/swinging drawbar
- Heavy duty fixed/swinging drawbar with three hitch heights
- Welded rear extension with pintle hook
- Category III, 3-point hitch
- Fifth wheel hitch
- Regular or inverted 4-inch gooseneck ball
- 40,000-lb hydraulic winch on rear frame
- Front push bumper

TIRES

- (4) 23.1X26, R1, 12-PLY
- Heavy duty one-piece rims

Optional:

- 18.4X38, R2, 8 PLY
- 23.1X26, R2, 12 PLY
- 23.1X34, R1, 8 PLY 81" (2.06M) track
- 600/65R34, R-1W 81" (2.06M) track
- 520/85R42, R2
- 710/70R38, R-1W

2018

GAME Equipment reserves the right to change specifications without notice. Some photos may contain optional equipment.

85ATX

4x4 ARTICULATED TRACTOR 280 HP (208 KW) / 260 HP (194 KW)

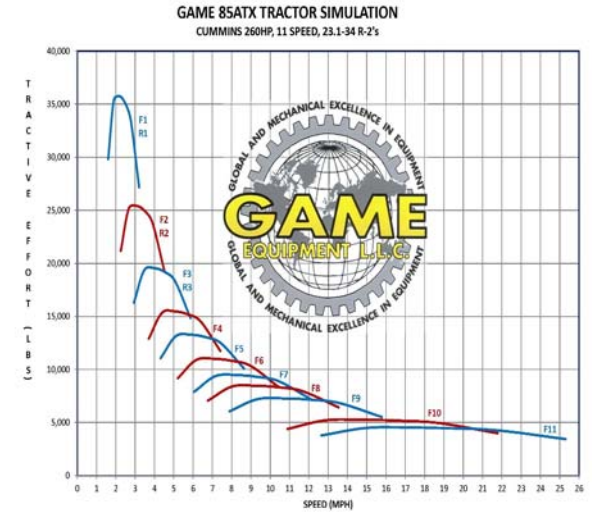
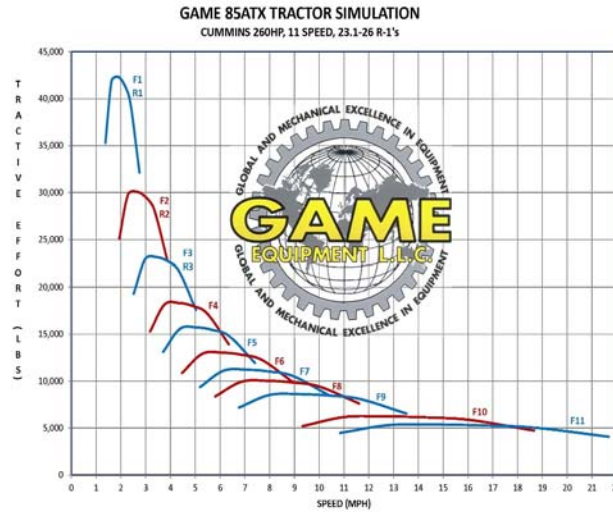
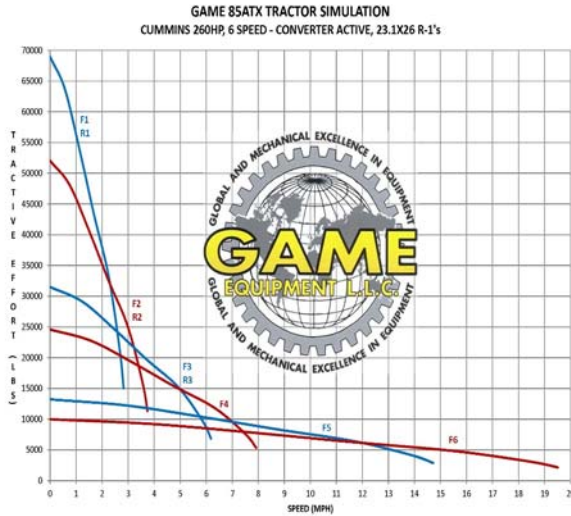

STANDARD TIRE SIZE	A - IN(MM)	B - IN(MM)	C - IN(MM)	D - IN(MM)	E - IN(MM)	F - IN(MM)	G - IN(MM)	H - IN(MM)
23.1X26, R1,12PLY	23.9 (607)	17.3 (439)	138.2 (3511)	245.7 (6241)	166.5 (4229)	138.4 (3515)	82.0 (2083)	106.7 (2695)

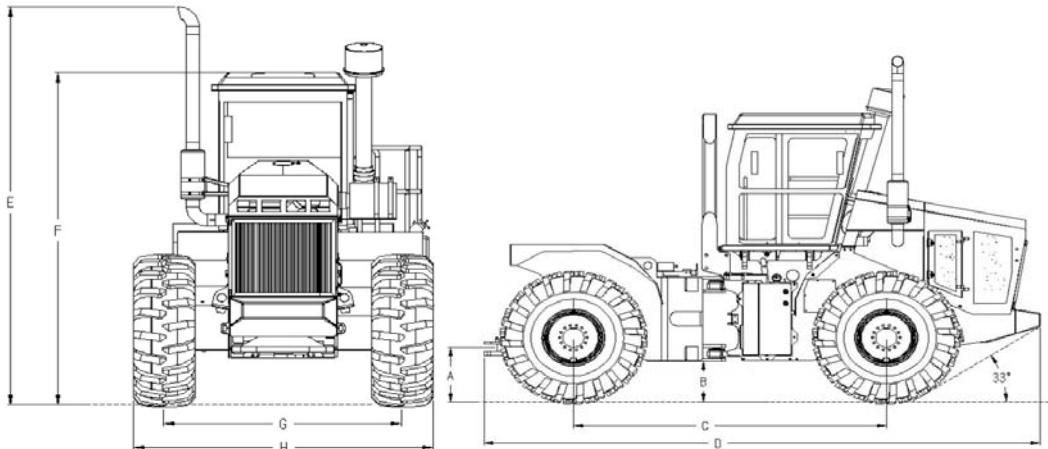

Specifications:

Unladen Tractor Weight.....28,000–32,000 LBS (12,727-14,545 KG)

Unladen Weight Distribution.....58% Front Axle 42% Rear Axle

Steering on 23.1x34 tires.....Inner Turning Radius 116" (2946 mm)
SAE Turning Radius 211" (5359 mm)
Clearance Radius 223" (5664 mm)

GAME Equipment reserves the right to change specifications without notice. Some photos may contain optional equipment.