

4475VSX

VEGETABLE SPRAYER 121 HP (90 KW) / 99 HP (74 KW)



Game Equipment LLC 3322 Hwy 308 Napoleonville, LA USA 70390-8904 Ph: 985-369-9292 Fax: 985-369-9595 www.gameeq.com

4475VSX VEGETABLE SPRAYER 121 HP (90 KW) / 99 HP (74 KW)

ENGINE

- Cummins QSF 3.8, Tier IV, Stage 5 electronic engine, 121 HP (90 KW) @ 2,200 RPM, Peak torque of 369 FT-LB (500 NM) at 1,500 RPM
- In line 4-cylinder, four stroke, compression ratio
- 229 cubic inch (3.8 liter) displacement
- Severe dust, dry, dual stage air cleaner with service indicator
- Spinning type dust pre-cleaner with automatic dust ejector
- Primary fuel/water separator with secondary fuel filter
- Heavy duty muffler
- Large tropical radiator and hydraulic oil coolers are 8 fins per inch and rubber isolator mounted
- 160-Ampere alternator

Export Only Option:

- John Deere 4045T, 99 HP @ 2,500 RPM mechanical engine

HYDROSTATIC DRIVE

- Hand hydrostatic control
- Two heavy duty, bi-directional, hydrostatic, variable displacement, axial piston pumps
- (4) Two-speed, hydrostatic motors:
 - * Top speed 14.6 MPH
 - * Low speed 9.0 MPH
- Four wheel drive
- 9.5 R36, R-1 front tires
- 9.5 R48, R-1 rear tires
- Brakes on all four wheels

CHASSIS

- Solid welded tubular frame
- Air conditioned cab (*Cab is not certified or intended to provide dermal, contact, or inhalation protection against chemicals. Operator must wear all protection equipment in compliance of product labeling of chemicals used.*)
- 30-gallon fuel tank
- 41 inches crop clearance
- 400-gallon poly tank
- Hydraulically adjustable wheel spacing
- (3) 1" 600 PSI rate, stainless steel spray valves
- 1" 600 PSI rated, stainless steel bypass valve when boom valves are turned off
- Hydraulically driven 1.5" X 1.25 centrifugal pump for agitation

STANDARD SPECIFICATIONS

- Wheel spacing 64" to 80" centerlines
- 40' boom (tip to tip)
- Hydraulically driven 280 PSI diaphragm pump for spray
- Raven control system with SCS 4400 console
- LED lighting

OPTIONS

- Wheel spacing 60" to 80" centerlines
- Wheel spacing 68" to 84" centerlines
- Boom wing tilt
- No Boom
- Additional hydraulic and electrical needed for wing tilt with "No Boom" option
- Pair of 2' boom extensions
- Stainless steel centrifugal pump for spray
- 700 PSI diaphragm pump
- Raven Envizio/Switch Pro console
- Raven Viper 4/Switch Pro console
- Stainless steel tank, fittings, hoses, strainers, valves, agitation centrifugal pump, etc. Only the diaphragm pump and relief are not stainless steel

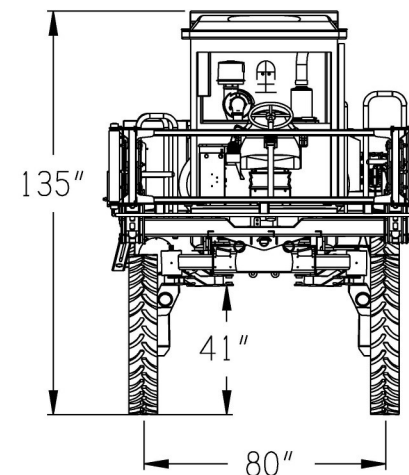

10/10/219

GAME Equipment reserves the right to change specifications without notice. Some photos may contain optional equipment.